



RG-TET310-1

Ranger Swing Barrier Bi-directional Turnstile



RANGER



Smooth & Reliable Operation

Stable, low-noise operation.



Advanced Security Features

Anti-tailgating, anti-reverse and automatic reset.



Automatic Reset Function

Automatically relocks if no one passes within the set time.



Infrared Anti-Clipping

Prevents accidents during gate operation.

*All image and specification is subject to change without prior notice.



Technical Data	RG-TET310-1
Size (L*W*H)	1400*160*980mm
Material	Top $\delta=1.2\text{mm}$ / body $\delta=0.9\text{mm}$
Filling panel material	8mm clear acrylic
Arm material	10mm clear acrylic
Pass width	600-900mm
Height from ground (upper part)	820mm
Height from ground (lower part)	200mm
Movement	Brushless movement of swing gate
Power supply	24V 150W
Input voltage	AC100V~240V,50/60HZ
Drive unit	DC brushless motor
Pass rate	35-50 persons/minute
Open speed	0.5s/1.5s
Sensor	6 pairs
Indicator light	RGB light
Control unit	Brushless control system
Noise	$\leq 65\text{dB}$
Temperature	$-20^{\circ}\text{C}\sim+70^{\circ}\text{C}$
Humidity	$\leq 90\%$ No condensation
IP	P4X
Environment	Indoor and outdoor (outdoor with canopy)

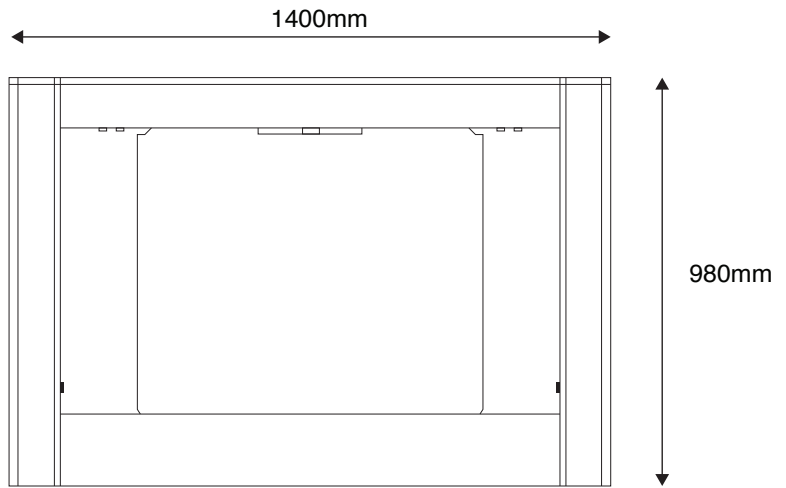
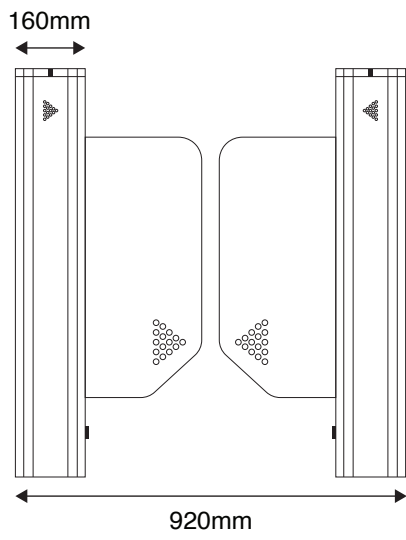

Ordering Info

Model

RG-TET310-1